

REVISIONS

SCHEDULES:

ALL DIMENSIONS ARE IN mm
DO NOT SCALE THE DRAWING

DRG.No.
ZNR/192100/MX

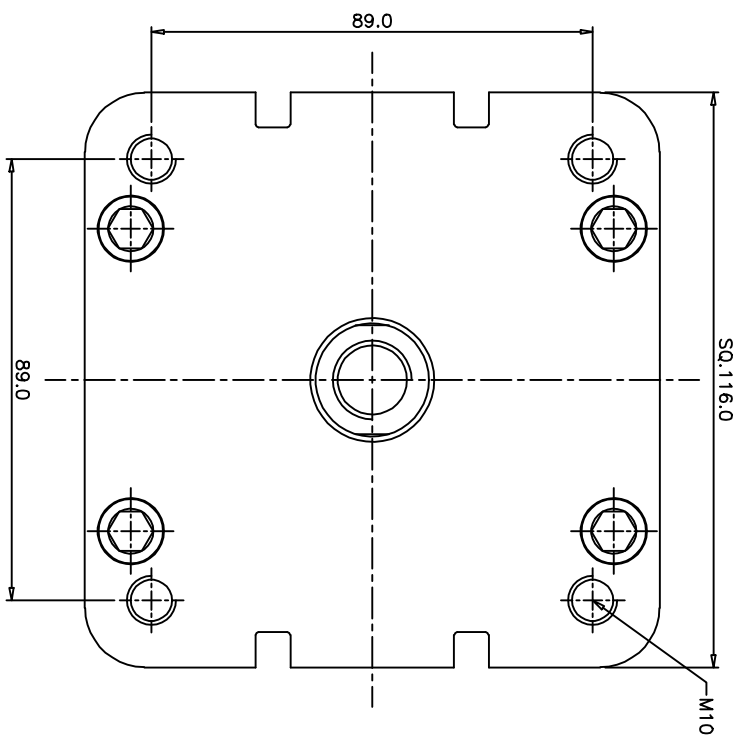

TECHNICAL DATA

- 1. CYLINDER TYPE : DOUBLE ACTING ISO/VDMA COMPACT CYLINDER
- 2. BORE DIA : 100
- 3. PISTON ROD DIA : 25
- 4. STROKE : 25
- 5. OPERATING PRESSURE : 1 to 10 bar
- 6. OPERATING TEMP.MAX. : -5°C + 80°C

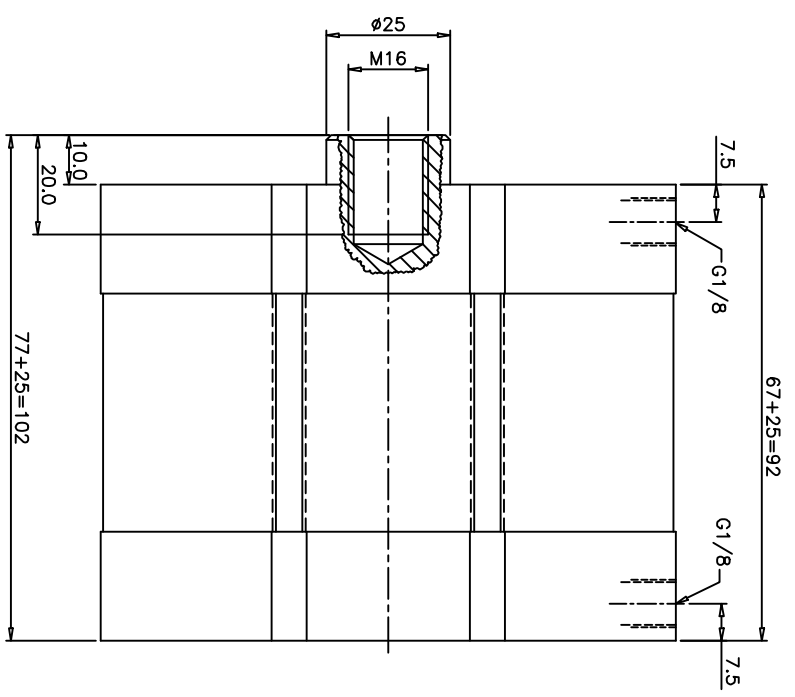

MATERIAL OF CONSTRUCTION

- 1. END COVERS, PISTON : ANODISED ALUMINIUM ALLOY
- 2. BARREL : ANODISED ALUMINIUM ALLOY
- 3. PISTON ROD : STAINLESS STEEL (MARTENSITIC)
- 4. PISTON ROD SEALS : POLYURETHENE
- 5. PISTON SEALS & O-RINGS : NITRILE RUBBER

NUCON INDUSTRIES PRIVATE LIMITED

ASSEMBLY:

100 mm BORE 25mm STROKE COMPACT CYLINDER

SCALE: 1:1 TITLE:

DATA SHEET



DRAWN	V.VINAY	19.11.2008
CHECKED		
APPROVED		
DRG.No.	ZNR/192100/MX	
SHEET	OF	