

REVISIONS

SCHEDULES:

ALL DIMENSIONS ARE IN mm  
DO NOT SCALE THE DRAWING

DRG.No.  
DATA.ZKM/30001

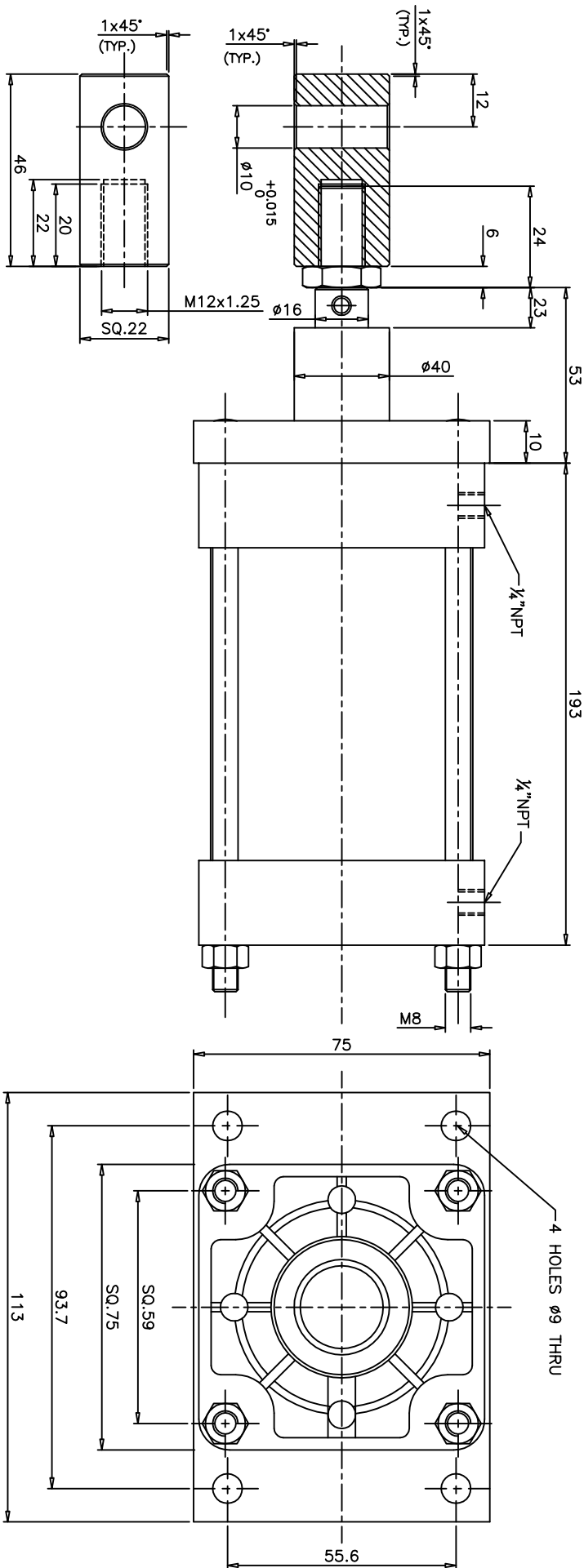

**TECHNICAL DATA**

- CYLINDER TYPE : DOUBLE ACTING WITH BOTH ENDS CUSHIONED
- BORE DIA : 63
- PISTON ROD DIA : 16
- STROKE : 80
- OPERATING PRESSURE : 2 - 10 bar
- OPERATING TEMP. MAX. : + 80°C
- MOUNTINGS : FRONT FLANGE MTG. STYLE-G (SPL.)  
: ROD CLEVIS MTG. STYLE-F (SPL.)

REMOVE BURRS AND SHARP CORNERS

**NUCON INDUSTRIES PRIVATE LIMITED**

GENERAL TOLERANCES

Dimensions	0.5	6	30	120	400
Tolerances ±	0.1	0.2	0.3	0.5	0.8
Angular ±1/2°	Concentricity φ 0.1				

MATERIAL:

FINISH:

ASSEMBLY: 63mm BORE 80mm STROKE STAINLESS STEEL CYLINDER

DRAWN : T.Prabhakar / 30.07.2006

CHECKED

APPROVED

SCALE: NTS

TITLE:

DATA SHEET

DRG.No.  
DATA.ZKM/30001

SHEET OF