

REVISIONS

SCHEDULES:

ALL DIMENSIONS ARE IN mm
DO NOT SCALE THE DRAWING

DRG.No.
DATA.ZRM/60001

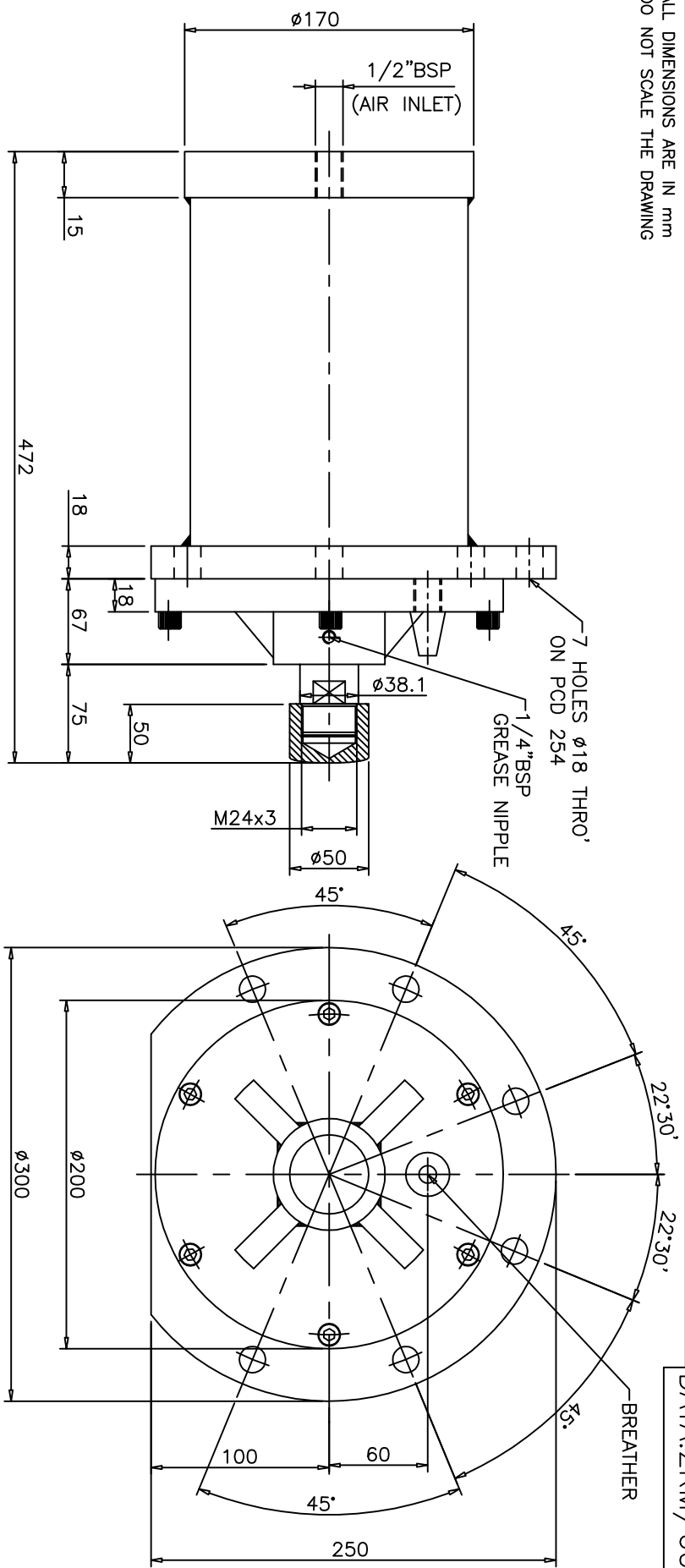

TECHNICAL DATA

- 1. CYLINDER TYPE : SINGLE ACTING NON CUSHIONED (STEEL BARREL)
- 2. BORE DIA : 150
- 3. PISTON ROD DIA : 38.1(EN-8 WITH HARD CHROME PLATED)
- 4. STROKE : 265
- 5. OPERATING PRESSURE : 2-10kg/cm²
- 6. WORKING PRESSURE : 5kg/cm²
- 7. OPERATING TEMP.MAX. : + 150 °C
- 8. SEALS : VITON
- 9. MOUNTING : FRONT FLANGE MTG.(SP1)

NUCON INDUSTRIES PRIVATE LIMITED

REMOVE BURRS AND SHARP CORNERS

ASSEMBLY:		150mm BORE 265mm STROKE WELDED CONSTRUCTION NON CUSHIONED CYLINDER	
SCALE: NTS		TITLE:	
DRAWN		D.SATISH	
CHECKED			
APPROVED			
DRG.No.		DATA.ZRM/60001	
SHEET		OF	

DATA SHEET