

REVISIONS

SCHEDULES:

ALL DIMENSIONS ARE IN mm
DO NOT SCALE THE DRAWING

DRG.No.
ZNRA/192050/M

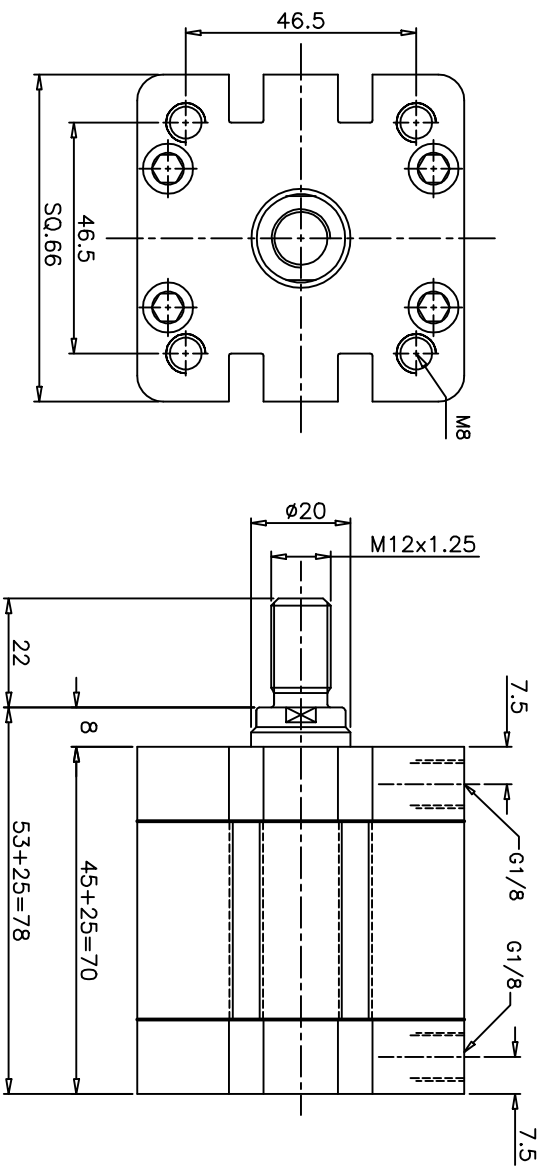

TECHNICAL DATA

- 1. CYLINDER TYPE : DOUBLE ACTING ISO/VDMA COMPACT CYLINDER
- 2. BORE DIA : 50
- 3. PISTON ROD DIA : 20
- 4. STROKE : 25
- 5. OPERATING PRESSURE : 1 to 10 bar
- 6. OPERATING TEMP.MAX. : -5°C + 80°C

MATERIAL OF CONSTRUCTION

- 1. END COVERS,PISTON : ANODISED ALUMINIUM ALLOY
- 2. BARREL : ANODISED ALUMINIUM ALLOY
- 3. PISTON ROD : STAINLESS STEEL (MARTENSITIC)
- 4. PISTON ROD SEALS : POLYURETHENE
- 5. PISTON SEALS & O-RINGS : NITRILE RUBBER

NUCON INDUSTRIES PRIVATE LIMITED

ASSEMBLY:		DRAWN	V.VINAY	19.11.2008
50 mm BORE 25mm STROKE COMPACT CYLINDER		CHECKED		
SCALE: NTS TITLE:		APPROVED		
DATA SHEET		DRG.No.	ZNRA/192050/M	
		SHEET	OF	